

# MPD-152 Motor Protection Device



## Features

- Auto/ Manual/ ZVR (Zero Value Reset) Reset Function
- True RMS Measurement
- User Selectable Trip Time

### Protection Available

- |                           |                     |
|---------------------------|---------------------|
| ▶ Over/Under Voltage      | ▶ Current Unbalance |
| ▶ Over/Under Current      | ▶ Phase Loss        |
| ▶ Over/Under Frequency    | ▶ Lock Rotor Point  |
| ▶ Single Phase Prevention | ▶ Phase Sequence    |
| ▶ Short Circuit           | ▶ Neutral Loss      |

## Specification

<b>Input Voltage</b>	30 to 300V AC (L-N) 50 to 520V AC (L-L)
<b>Input Current</b>	5A to 6000A/5A CT Ratio Selectable
<b>Network Connection</b>	3Ø-4W/3Ø-3W Selectable
<b>Measurement Parameter</b>	Voltage : $V_{L-L}(3Ø-3W), V_{L-N}(3Ø-4W)$ Current : All Phase Current ( $I_R, I_Y, I_B$ ) Frequency : System Frequency
<b>Accuracy</b>	Class 1.0
<b>Certificate</b>	

## LED Indication & Keys

<b>LED 1</b>	Relay LED
<b>LED 2</b>	Volt LED
<b>LED 3</b>	Amp LED
<b>LED 4</b>	KA (Kilo Ampere) LED
<b>KEYS</b>	SET, INC, DEC, RESET

## Application

Electrical Control Panel  
Submersible Pump  
Road Construction Panel  
MCC Panel  
Industrial Chiller And HV AC System  
D.G. Set

## Input

Voltage AC	
Direct Voltage	30 To 300V ( L - N ) 50 TO 520V ( L - L )
Burden	<0.2 VA
Current AC	
Primary CT Ratio	5 To 6000A Programmable
Secondary Current AC	0.5 A to 5 Amp
Burden	<0.2 VA
Overload	UP to 6A Continuous
Starting Current	0.5 Amp
Frequency	45.0 TO 65.0 Hz

## Auxiliary Power Supply

Power Supply	100 to 270V AC, 50Hz
Burden	3VA

## Physical

Mounting Type	Din Rail Mount
Size ( H x W x D )mm	75 X 55 X 110
Front Bezel ( H x W ) mm	75 X 55
Depth Behind panel ( mm)	52
Material	ABS
Weight (gm)	347

## Display , Keys & LED

Display	3 Digit, 3Line 7 seg. 0.28" Red LED Display
Key	SET, INC, DEC, RESET
LED	R(Relay),V(Voltage), I(Amp),KA(KiloAmp)

## Environmental

Working Temperature	0 to 55 °C
Storage Temperature	0 to 55 °C
Relative Humidity	95% RH Non-condensing
Warm up time	5 minutes

## Calculated Parameter

Voltage	V
Current	All Phase Amp
Frequency	System Frequency

## Accuracy

Class 1.0

## Mechanical Dimension

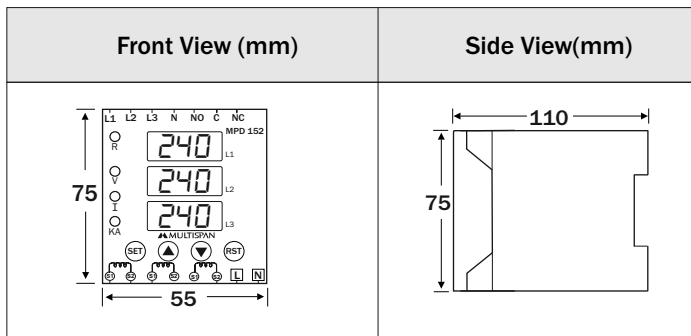

## Connection Diagram

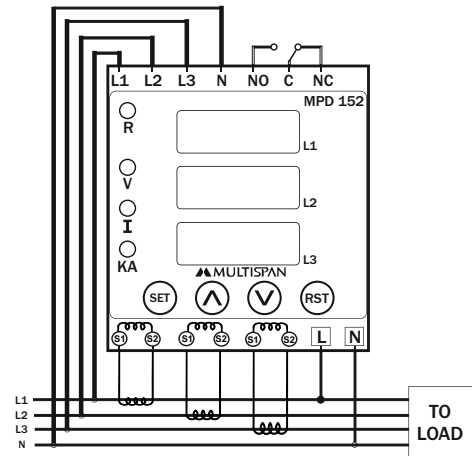

# Ordering Information

Part No.	Input Current	Supply Voltage
MPD-152-A2-00	5 to 6000 Amp Primary CT Selectable	100-270V AC
MPD-152-A2-01	30A with DIN 30 - 3 CT	100-270V AC
MPD-152-A2-02	60A with DIN 60 - 3 CT	100-270V AC
MPD-152-A2-03	30A with DIN 30AN CT	100-270V AC
MPD-152-A2-04	60A with DIN 60AN CT	100-270V AC
MPD-152-A2-05	100A with DIN 100AN CT	100-270V AC

## Control Function

### Unbalance

Power On:- 5 Sec  
Initial Time Delay:- 5 Sec  
Unbalance:- Enable

Unbalance Percentage:- 50%  
Unbalance Time:- 5 Sec  
Relay Fault:- OFF  
Reset Mode:- Auto  
Reset Time:- 5 Sec

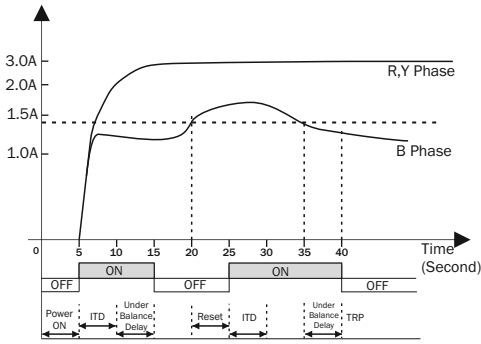

### Under Current

Power On:- 5 Sec  
Initial Time Delay:- 5 Sec  
Under Current:- Enable

Under Current:- 3.0A  
Under Current time:- 5 Sec  
Relay Fault:- OFF  
Reset Mode:- Auto  
Reset Time:- 5 Sec

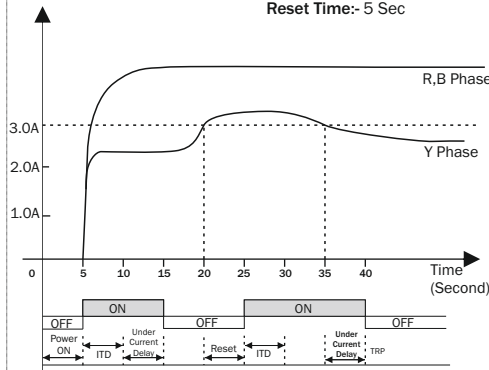

### Single Phase Prevention (SPP)

(For Voltage)

Power On:- 5 Sec  
Initial Time Delay:- 5 Sec  
SPP:- Enable

SPP Time:- 5 Sec  
Reset Time:- 5 Sec  
Reset Fault:- OFF  
Fault Reset mode:- Auto

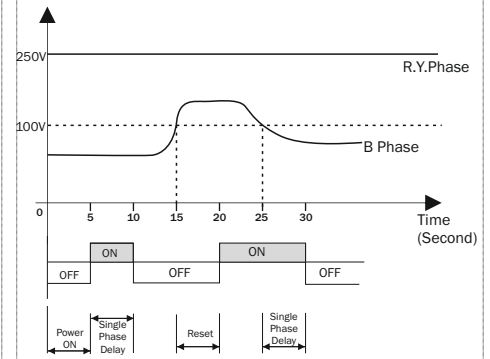

### Under Voltage

Power On:- 5 Sec  
Initial Time Delay:- 5 Sec  
Under Voltage:- Enable

Under Voltage:- 380V  
Under Voltage time:- 5 Sec  
Relay Fault:- OFF  
Reset Mode:- Auto  
Reset Time:- 5 Sec

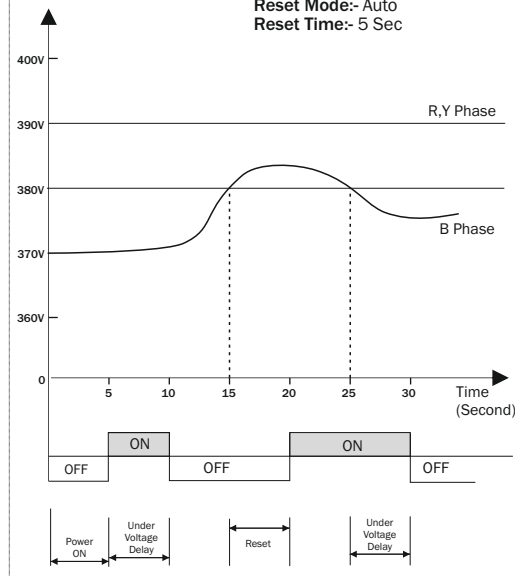

### Lock Rotor Point

Power On:- 5 Sec  
Initial Time Delay:- 5 Sec  
Lock Rotor Point:- Enable  
Over Current:- Disable

Lock Rotor Point:- 2.0  
Over Current Value:- 2.0A  
Relay Fault:- OFF  
Reset Mode:- Auto  
Reset Time:- 5 Sec

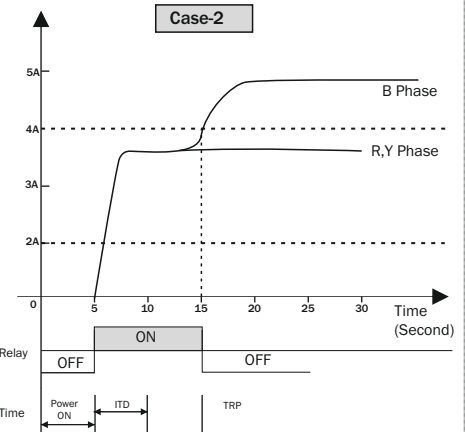
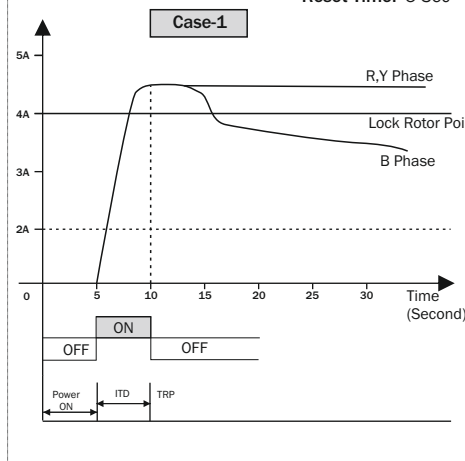

Multispan reserves the right to change specifications without prior notice. Printing and typographical errors reserved.

Product improvement and upgrade is a constant procedure. So for more updated operating information & support contact us.

**Multispan Control Instruments Pvt. Ltd.**

72/B,Phase 1, GIDC Estate,Vatva,Ahmedabad-382445,Gujarat,India.

+91-7575805463/7623001206

support@multispanindia.com

Follow us



www.multispanindia.com